



DC 550 SK







DC 550M

DC 550P

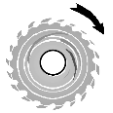
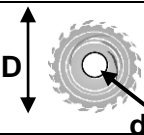
DC 550PB

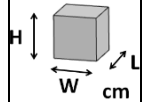
TEKNİK ÖZELLİKLER - TECHNICAL FEATURES - ТЕХНИЧЕСКИЕ ОСОБЕННОСТИ

								
		3000 dev/dak. RPM	D = 550 mm d = 30 / 32 mm	6-8 BAR	54 Lt/dak. Lt/min.	W = 125 L = 511 H = 188	kg	kg
DC 550 M	3 kW 50 Hz x 2 400V AC 3P PE	3000 dev/dak. RPM	D = 550 mm d = 30 / 32 mm	6-8 BAR	54 Lt/dak. Lt/min.	W = 125 L = 511 H = 188	1415	1690
DC 550 P	3 kW 50 Hz x 2 400V AC 3P PE	3000 dev/dak. RPM	D = 550 mm d = 30 / 32 mm	6-8 BAR	56 Lt/dak. Lt/min.	W = 125 L = 511 H = 188	1440	1715
DC 550 PB	3 kW 50 Hz x 2 400V AC 3P PE	3000 dev/dak. RPM	D = 550 mm d = 30 / 32 mm	6-8 BAR	56 Lt/dak. Lt/min.	W = 125 L = 511 H = 188	1480	1755
DC 550 SK	3 kW 50 Hz x 2 400V AC 3P PE	3000 dev/dak. RPM	D = 550 mm d = 30 / 32 mm	6-8 BAR	56 Lt/dak. Lt/min.	W = 125 L = 511 H = 188	1470	1745

KESME DİYAGRAMI – CUTTING DIAGRAM – ДИАГРАММА ВЫПИЛИВАНИЯ

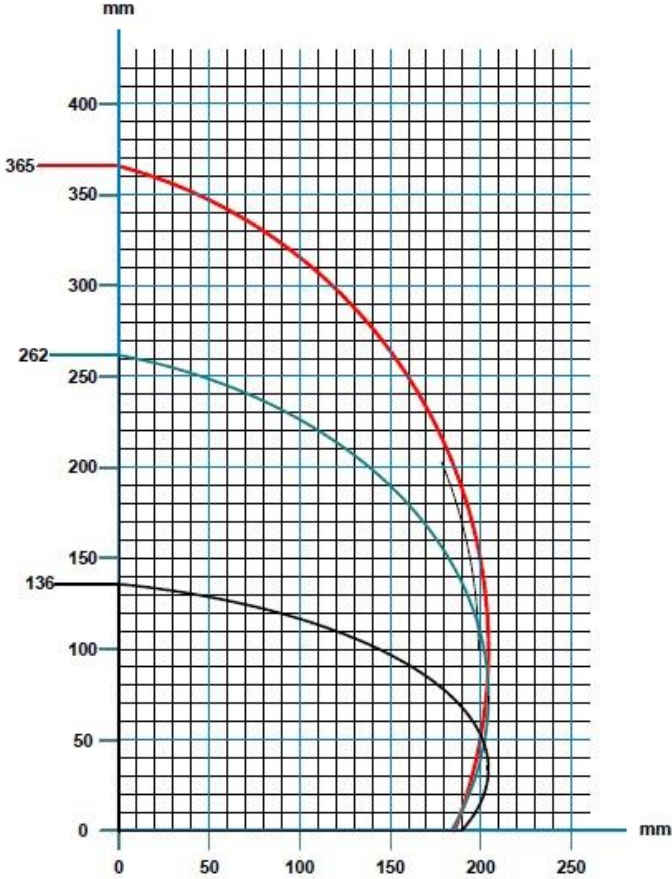

- 90°
- 45°
- 22,5°

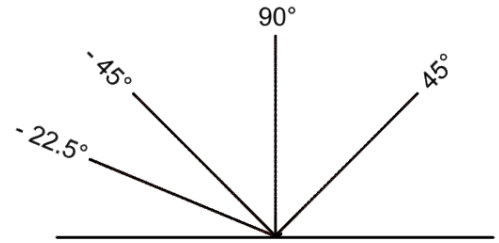

Testere açılarındaki (-) değerler testerenin dışı olan açılarını belirtmektedir.

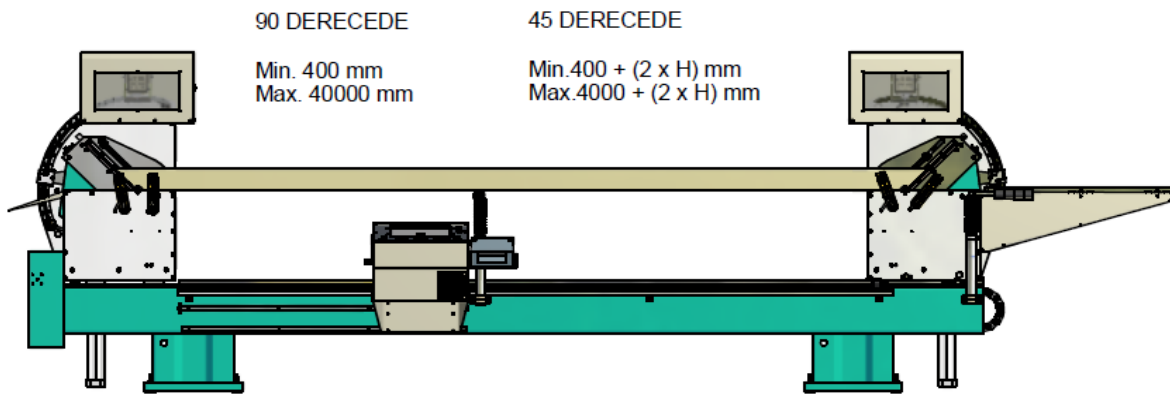
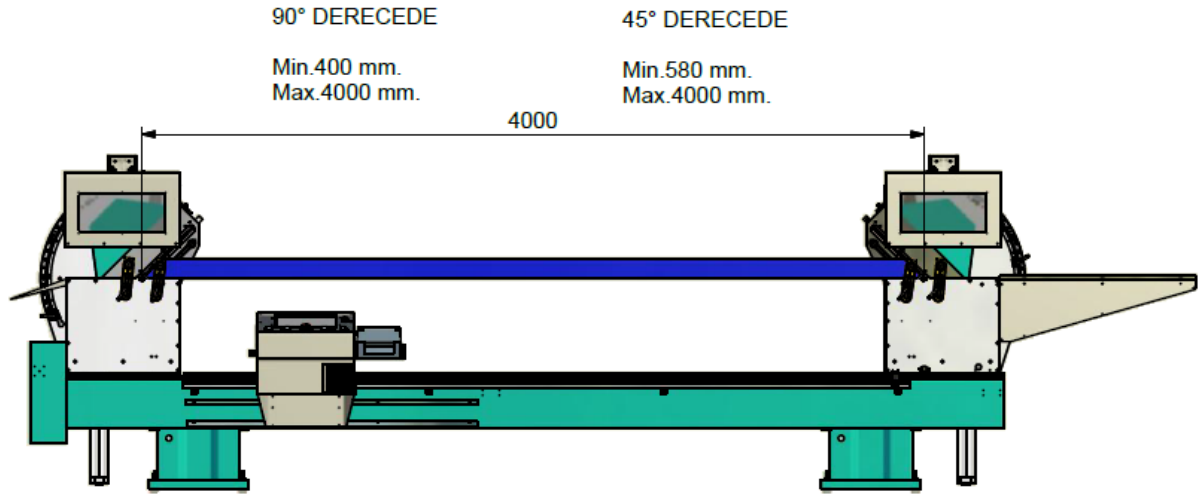

BOYUTLAR – DIMENSIONS – РАЗМЕРЫ

RESİM-PICTURE-РИСУНОК 1

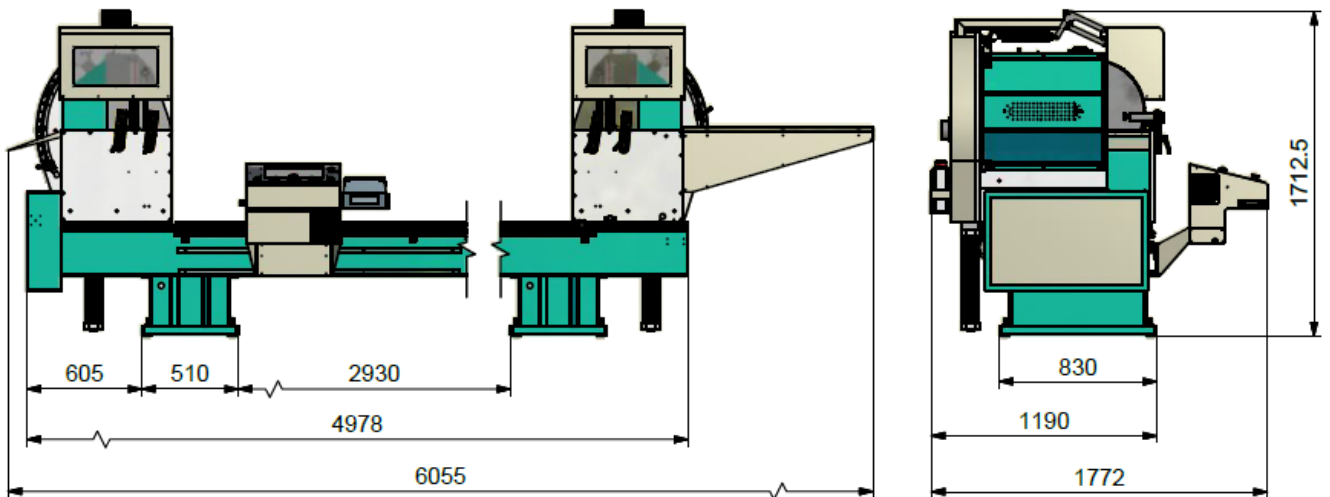

RESİM-PICTURE-РИСУНОК 2

PARÇA LİSTESİ - PART LIST - ПЕРЕЧЕНЬ ДЕТАЛЕЙ

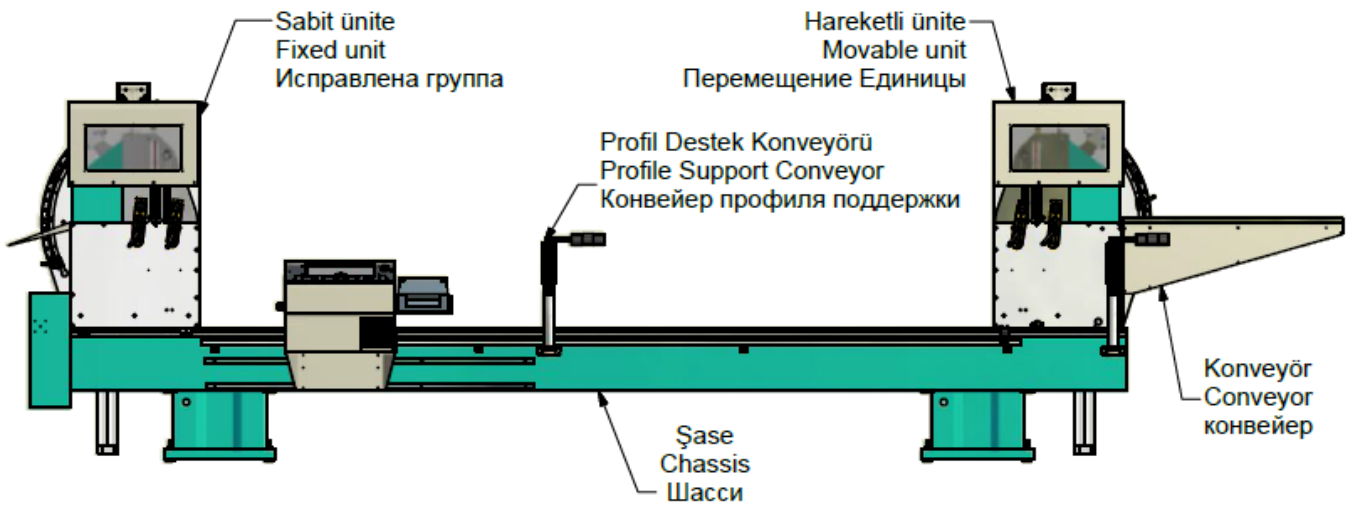

RESİM-PICTURE-РИСУНОК 3

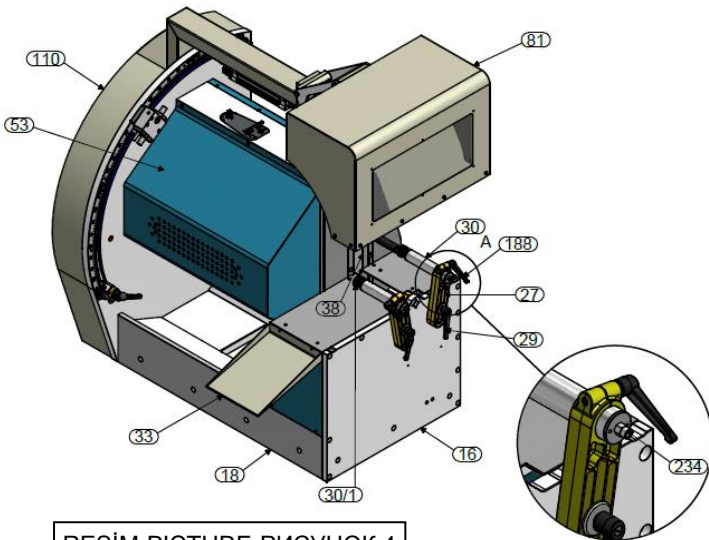

RESİM-PICTURE-РИСУНОК 4

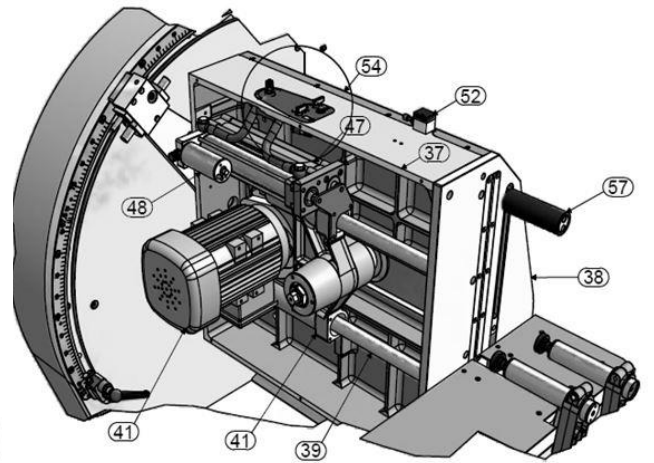

RESİM-PICTURE-РИСУНОК 5

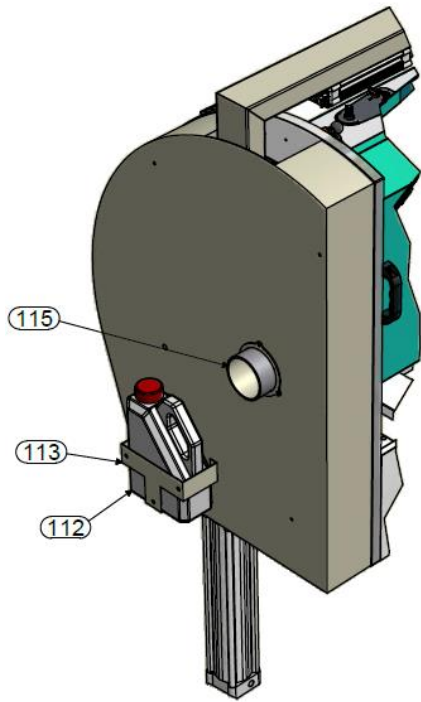

RESİM-PICTURE-РИСУНОК 6

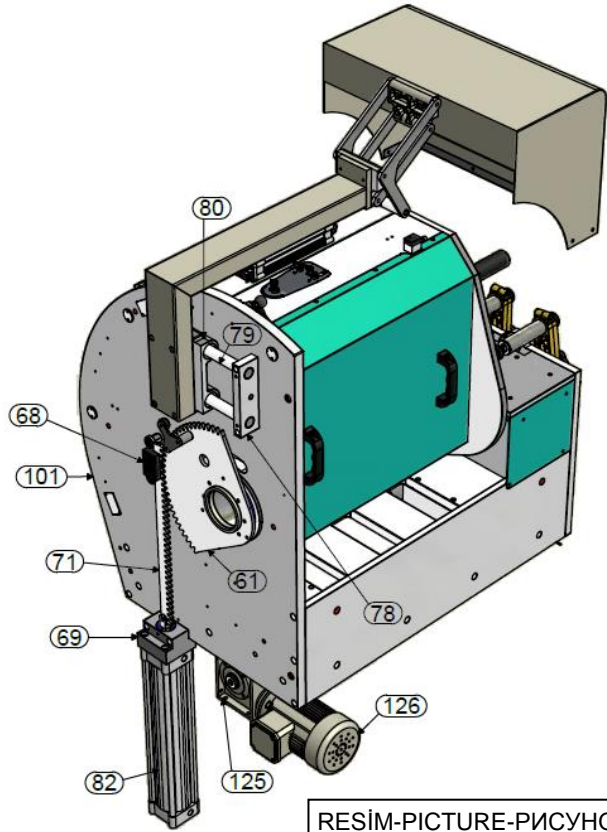

RESİM-PICTURE-РИСУНОК 7

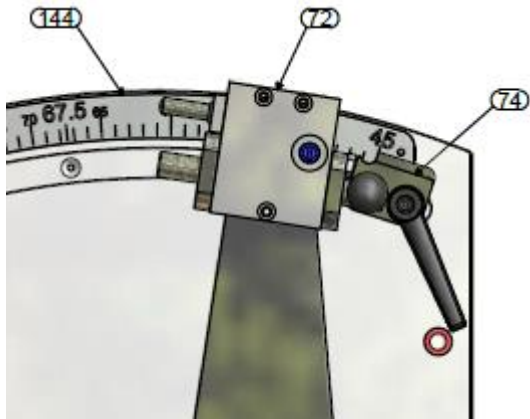

RESİM-PICTURE-РИСУНОК 8

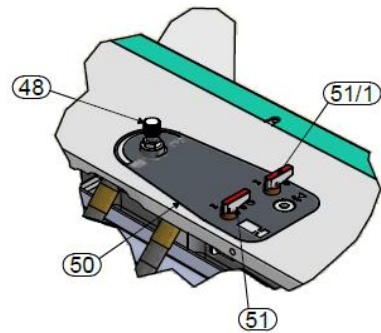

RESİM-PICTURE-РИСУНОК 9

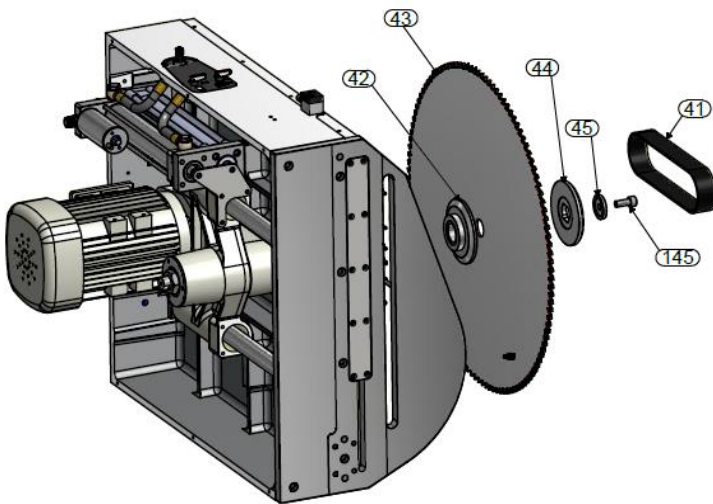

RESİM-PICTURE-РИСУНОК 10

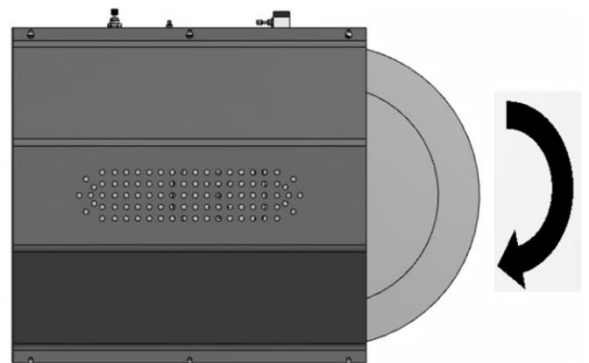

RESİM-FIGURE-РИСУНОК 11

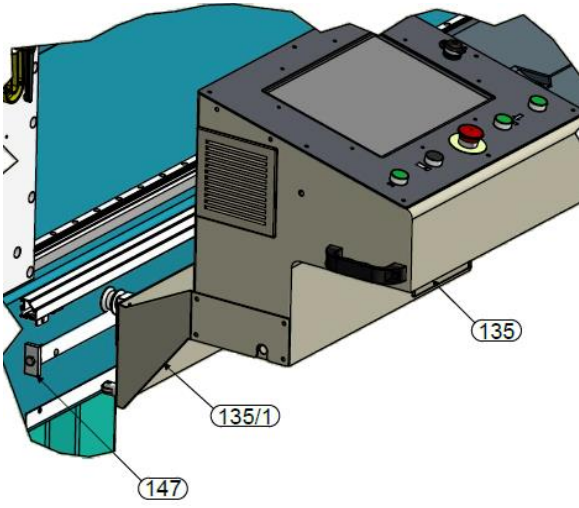

RESİM-FIGURE-PICTYHOK 12

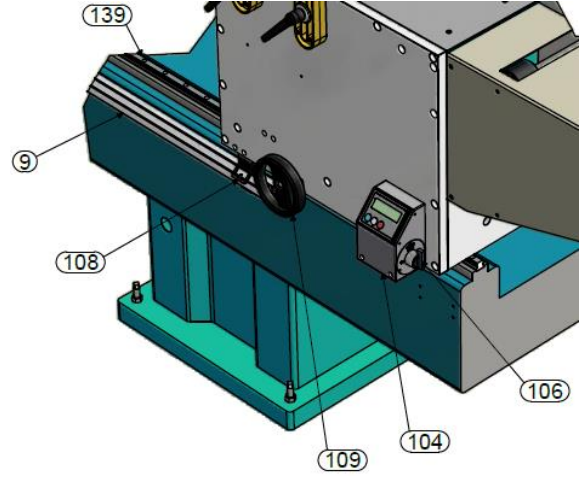

RESİM-FIGURE-PICTYHOK 13

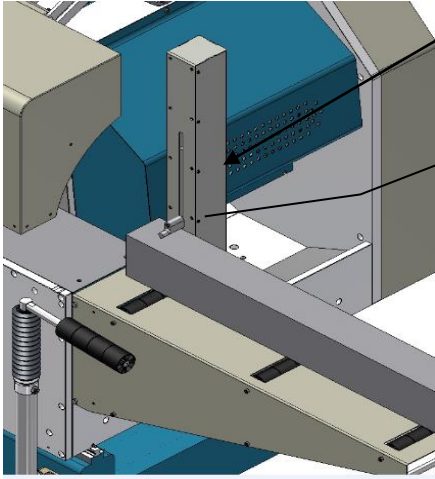

RESİM-FIGURE-PICTYHOK 14

Profil yüksekliğini ölçme sistemi
Profile height measuring system
Profil yüksekliğini ölçme sistemi

148

149



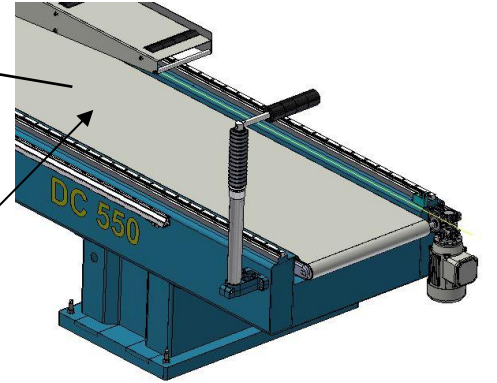



Talaş konveyörü
Chip conveyor

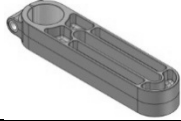

RESİM-FIGURE-PICTYHOK 15

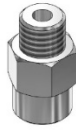
NO номер	СТОК КОДУ / CODE ПОРЯДОК КОД	АДЕТ / QTY КОЛИЧЕСТВО	NO номер	СТОК КОДУ / CODE ПОРЯДОК КОД	АДЕТ / QTY КОЛИЧЕСТВО
9	3UA670060-0001	1	50	2ET022441-0053	1
16	2TU012410-0118/0119	1	51	1PN130000-0014	2
18	2TU012410-0120	2	52	1PN010000-0012	2
23	2TU011441-0682/0683	1	53	1SA030000-0070	2
29	3UA04030-0001	4	57	3UA670030-0320	2
33	1SA050000-0213	1	68	2TU013210-0079	2
38	2TU011410-0073/0074	1	69	2TU012210-0649	2
39	2TU015010-0073	4	71	2TU011441-0462	2
41	1EL070001-0006	2	72	3UA680030-0006	2
42	2TU011110-0983	2	74	3UA680030-0005	2
43	1SK010000-0046	2	78	2TU012210-0646	4
44	2TU011110-0983	2	79	2TU015010-0072	4
45	2TU011110-0986	2	80	2TU012510-0356	2
47	1PN020000-0178	2	81	1SA030000-0069	2
48	3UA670030-0013/0005	1	82	1PN020000-0144	2
80	2TU012510-0356	2	113	2TU011410-0014	2
81	1SA030000-0069	2	115	3UA670030-0001	2
82	1PN020000-0144	2	125	1EL070030-0007	1
101	2TU012410-0114/0115	1	126	1EL070001-0010	1
104	2TU012510-0388	1	135	1SA020000-0053	1
106	3UA690030-0113	1	135/1	2TU011441-0684	1
108	2TU011441-0641	1	139	1SR080000-0121	2
109	2TU012010-0004	1	144	2TU011441-0724/0725	1
110	1SA030000-0071 /0072	1	145	1SC021000-0003	2
112	1PL010000-0020	2	147	2TU011210-0087	2
148	3UA670030-0331	1	149	1HM010000-0002	1

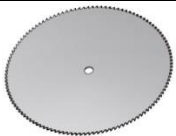
YEDEK PARÇA LİSTESİ / SPARE PART LIST / СПИСОК ЗАПАСНЫХ ЧАСТЕЙ

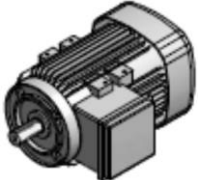
PARÇA NO PART NO НОМЕР	RESİM PICTURE РИСУНОК	STOK KODU / CODE ПОРЯДОК КОД	PARÇA ADI – PART NAME НАИМЕНОВАНИЕ ДЕТАЛИ
27		2TU012610-0044	MENGENE PİSTONU BAĞLANTISI CLAMP MOUNTING BRACKET
30		3UA060030-0013	PNÖMATİK MENGENE PNEUMATIC CLAMP
224		1PN140000-0005	1/8-6 REKOR 1/8-6 FITTING
188		3UA040030-0007	M8x32 PİPO M8x32 HANDLE
29		3UA040030-0001	M12*60 PİPO M12*60 HANDLE
43		1SK010000-0046	Ø 550 TESTERE BIÇAĞI Ø 550 SAW SAW BLADE
52		1PN010000-0012	SPRAYER SU PÜSKÜRTME VALF WATER SPRAY VALVE
38		2TU011441-0014	TESTERE KANAL LAMASI SAW CHUTE PLATE
41		1SR070000-0005	MOTOR KAYIŞI MOTOR BELT
30/1		1PL010000-0033	MENGENE PABUCU CLAMP FEET
41		1EL070001-0006 400V-415V (3P 50 Hz)	MOTOR MOTOR

